

# Vulcascot Cable Protectors

## Product Information



### PROFILE: SnapFit Multi Type BNC/1

Available in 9M and 3M lengths

Available in Black or Grey

A SnapFit product is perfect for securing any loose, straggling leads or cables where there is a potential danger of tripping and falling.

“Snap” open the membrane in the base of the profile, push in the cable and lay the protector in place.

Manufactured in the UK from a mix of natural and synthetic Rubbers.

- Fire tested to BS 476 Part 7 Class 3
- Halogen free in the event of fire
- Low smoke, non toxic and low fume emission levels
- Tested for non conductivity to BS903-C5, 500V
- UV stabilised for extended outdoor life
- All dimensions are nominal and subject to manufacturing tolerances

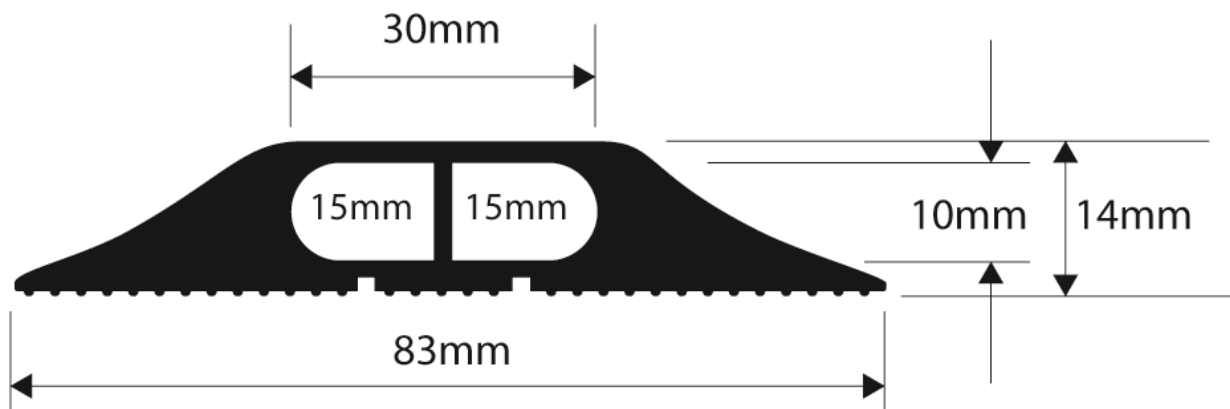

#### Vulcascot Cable Protectors Limited

12 Norman-D-Gate, Bedford Road,  
Northampton. NN1 5NT



Tel: 0800 0352842

Intl: +44 (0)1604 212973

Fax: +44 (0)1604 632344

Email: [sales@vulcascot.co.uk](mailto:sales@vulcascot.co.uk)

Web: [www.vulcascot.co.uk](http://www.vulcascot.co.uk)