



Science.
Applied to Life.™



**Lightweight & slim design –
delivering a world of comfort to you.**

The balanced and compact 3M™ Versaflo™ TR-300+ Powered Air Respirator is the key to easy-to-use, versatile, respirator systems for particulate environments.



The New 3M™ Versaflo™ Powered Air Turbo TR-300+

Thanks to comprehensive research and an in-depth understanding of your needs, we created the most advanced, versatile solution yet. Simply put: It's designed to help make breathing and working easier.

Lighter and smaller

The turbo is significantly lighter and thinner than 3M's existing belt-mounted turbo units, with a slim profile designed for use in tight spaces.

The weight of the turbo is approx. 1135 g (including particulate filter, high-capacity battery and standard belt). It also keeps its light weight close to the user's back, reducing the leverage effect that can cause turbos to feel heavier.

Straightforward, minimal maintenance

All maintenance can be done by hand. The battery, filter and pre-filter can all be changed quickly and easily by hand.

- ▶ The belt and turbo unit have smooth surfaces with facilitating fast wipe-downs for easier cleaning.
- ▶ IP53 rating. Suitable for use in decontamination shower.
- ▶ A window on the turbo allows instant identification of the installed filter.
- ▶ Durable brushless motor for superior reliability.

Comfort

Sophisticated electronics keep the factory-calibrated airflow at a minimum 170 l/min, eliminating the need for regular calibration by the user. Even as the battery discharges, or the filter becomes loaded with particulates, the unit delivers a steady flow of air.

The 2 selectable flow rate options – 185l/min and 205l/min – offer more comfort to the user.

Simple yet comprehensive controls

The 3M Versaflo Powered Air Turbo TR-300+ features a user-friendly design with intuitive, coloured interactive touch points, battery charge and particulate filter loading status indicators and audible and visual low-flow and low-battery indicators.

Convenient ways to buy.

Intelligent power

- ▶ The economy battery runs continuously for approx. 4.5 to 6h, while the high capacity battery runs for approx. 9 to 12h (with new filter and new fully charged battery in both cases). Recharging time is less than 3h for the standard battery (less than 3.5 h for the high-capacity battery).
- ▶ The lightweight lithium ion battery quickly charges and has no memory effect or heavy metals. It can be easily removed for charging.
- ▶ Intelligent chargers help maintain the optimum battery performance and are available in single-battery or four-battery stations.

Options for diverse environments

- ▶ Filters: Pre-filter, Particulate filter, Particulate filter that also reduces nuisance-level organic vapours*, Particulate filter that also provides protection against hydrogen fluoride, with performance up to

10 × Threshold Limit Value (TLV), as well as offering nuisance-level acid gas performance.*

- ▶ For welding and grinding applications, a spark arrestor reduces the risk that sparks and other hot materials will come in contact with the filter and motor.
- ▶ Belts: Standard webbing belt, coated easy-clean belt, spark-resistant leather belt for heavy-duty applications and braces and a backpack are also available.
- ▶ Standard and high-capacity battery.
- ▶ Single Charger and 4-Station Battery Charger kit.
- ▶ EN12941 TH2/TH3.

▶ 1 Starter Kit

3M™ Versaflo™ Powered Air Starter Kit TR-315E+ includes:

- ▶ TR-302E+ Powered Air Turbo
- ▶ TR-3712E P Filter
- ▶ BT-30 Length Adjusting Breathing Tube

- ▶ TR-325 Standard Belt
- ▶ TR-332 High Capacity Battery
- ▶ TR-341E Single Station Battery Charger
- ▶ TR-3600 Pre-Filter (x10)
- ▶ TR-971 Airflow Indicator
- ▶ TR-362 Spark Arrestor (x2)



▶ 2 Total Customisation

If you need full customisation of your 3M™ Versaflo™ Powered Air Turbo TR-300+ system, you can purchase all components separately (see tables on next page).

*Nuisance level refers to concentrations below the workplace exposure limit (WEL).



3M™ Versaflo™ Powered Air Respirator TR-300+ Components



Powered Air Turbo

TR-302E+	Includes:	TR-971 Air Flow Indicator TR-362 Spark Arrestor (x2)
----------	-----------	---------------------------------------------------------



Filters

Filter covers

TR-3712E Particle	TR-371+
TR-3802E Particle + Nuisance level organic vapour **	
TR-3822E Particle + Nuisance level acid gas (including Hydrogen Fluoride up to 10 x WEL)	



**Nuisance Odour refers to concentrations below the workplace exposure limit.

Batteries

TR-330 Standard Battery
TR-332 High Capacity Battery



Chargers

TR-341E Single Station Battery Charger Kit
TR-344E 4-Station Battery Charger Kit



Belts

TR-325 Standard Belt
TR-326 Leather Belt
TR-327 Easy Clean Belt



Spares & accessories

TR-971 Airflow Indicator	BPK-01 Backpack
TR-3600 Pre-Filter	TR-329 Braces
TR-362 Spark Arrestor	



Note: 3M does not accept responsibility or liability, direct, indirect or consequential, arising from reliance upon any information provided and the user should determine the suitability of the products for their intended use. Nothing in this statement will be deemed to exclude or restrict 3M's liability for death or personal injury arising from its negligence or fraudulent misrepresentation.

Personal Safety Division

3M United Kingdom plc
3M Centre
Cain Road, Bracknell
Berkshire, RG12 8HT
Tel: 0870 60 800 60
www.3M.co.uk/safety

3M Ireland Limited
The Iveagh Building
The Park
Carrickmines
Dublin 18
1 800 320 500

Please recycle. Printed in the UK. © 2016 3M.
All rights reserved. J347991



3M™ Versaflo™ Powered Air Respirator TR-300+

To maintain protection levels, optimize the effective lifetime of the system and avoid the additional cost of replacement, it is extremely important to carry out regular checks and maintenance on Powered and Supplied Air Respirators.

Before use

- ▶ Use indicator button to confirm battery charge
- ▶ Ensure filter is correctly fitted
- ▶ If spark arrestor and / or pre-filter are used, ensure they are clean
- ▶ Perform airflow check - insert Airflow Indicator Tube. Refer to turbo user instructions for information
- ▶ Perform alarm check. Refer to turbo user instructions for information
- ▶ Visually inspect for damage

Monthly

- ▶ Carry out all the 'Before Use' inspections and create a record of this monthly check for the turbo

After use

- ▶ Clean with cloth dampened with a mild solution of water and liquid household soap
- ▶ Disinfect surfaces with 3M™ 105 Wipes
- ▶ Store in a dry, clean area / locker away from direct sunlight, high temperatures and solvents

Every filter change

- ▶ Inspect filter and inner seal and replace if damaged
- ▶ Always properly install the filter into the turbo

Ordering consumables, repair parts and accessories

- ▶ To request a quote or place an order for these items, please contact your 3M Approved Distributor.

Further information and advice

- ▶ If you require additional guidance on the Care and Maintenance of your 3M Powered and Supplied Air Equipment, please contact the Helpline or your local 3M representative.

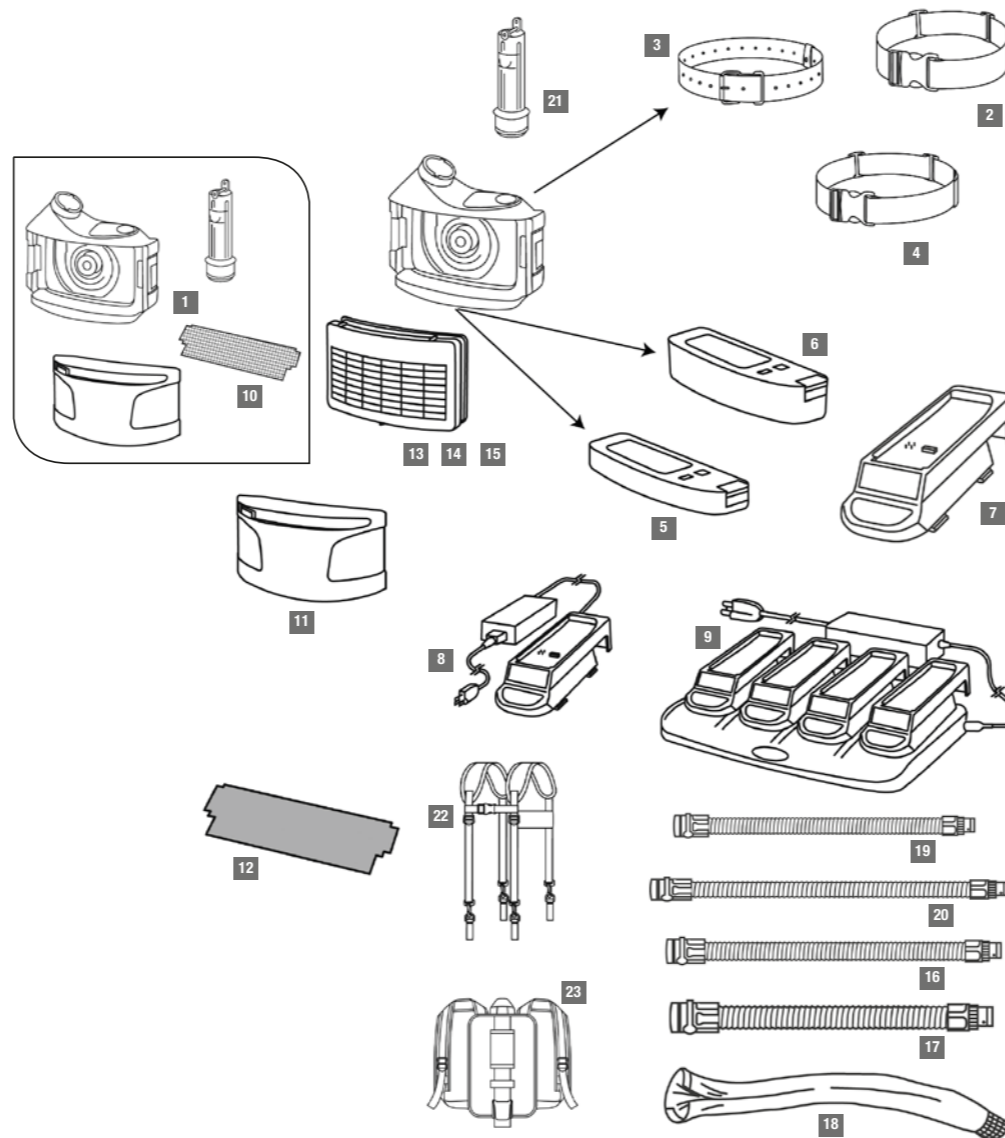

Description	Part No.
1 3M™ Versaflo™ TR-302E+ Powered Air Turbo Unit (complete with Filter Cover, Spark Arrestors (x2) and Air Flow Indicator)	TR-302E+
2 Standard Belt	TR-325
3 Leather Belt	TR-326
4 Easy-Clean Belt	TR-327
5 Standard Battery Pack	TR-330
6 High Capacity Battery Pack	TR-332
7 Battery Charging Cradle	TR-340
8 Single Station Charger Kit	TR-341E
9 4 Station Battery Charging Kit	TR-344E
10 Spark Arrestor	TR-362
11 Replacement Filter Cover	TR-371+
12 Pre-Filter	TR-3600
13 Particulate Filter	TR-3712E
14 P/Nuisance Level Organic Vapour Filter	TR-3802E
15 P/HF/Nuisance Level Acid Gas Filter	TR-3822E
16 Length Adjusting Breathing Tube	BT-30
17 Heavy Duty Rubber Breathing Tube	BT-40
18 Breathing tube cover – Flame and Heat Resistant, High Durability	BT-926
19 Short Lightweight Breathing Tube	BT-20S
20 Long lightweight Breathing Tube	BT-20L
21 Airflow Indicator	TR-971
22 Braces	TR-329
23 Backpack	BPK-01
Filter Surround Gasket	TR-380

Replace all damaged parts immediately to ensure correct levels of protection.

Personal Safety Division

3M United Kingdom plc
3M Centre
Cain Road, Bracknell
Berkshire, RG12 8HT
Tel: 0870 60 800 60
www.3M.co.uk/safety

3M Ireland Limited
The Iveagh Building
The Park
Carrickmines
Dublin 18
1 800 320 500

Please recycle. Printed in the UK.
© 2016 3M. All rights reserved.
J347991



Science.
Applied to Life.™



**Lightweight & slim design –
delivering a world of comfort to you.**

The balanced and compact 3M™ Versaflo™ TR-300+ Powered Air Respirator is the key to easy-to-use, versatile, respirator systems for particulate environments.

Introducing the new 3M™ Versaflo™ Powered Air Turbo TR-300+

The 3M Versaflo Powered Respirator System TR-300+ combines performance, protection and functionality with modern, stylish design and comfort. It is the key to easy-to-use, versatile, respiratory protection systems for particulate environments.

Features and Benefits:

Comfortable Airflow

- ▶ Two user selectable flow rates to maximise comfort: 185l/min and 205l/min
- ▶ Controlled airflow delivers steady flow as battery discharges or filter loads with particulates

Ease of Use

- ▶ Electronic audible and visual alarm in case of low battery and/or low air flow
- ▶ TR-300+ display shows battery charge status, particulate filter loading status during use as well as selected airflow
- ▶ Charge status is indicated by a useful LED display on the battery as well as the outer case
- ▶ No user calibration of turbo required

Comfort

- ▶ Light and small – extremely slim, lightweight, balanced design for comfort

Multiple Applications

- ▶ High efficiency filter captures hazardous dust, mist and fume plus options for nuisance level gases and vapours
- ▶ IP53 rating. Suitable for use in decontamination shower

Safety

- ▶ Approved to EN 12941, TH2 or TH3 depending on headtop

Filter

TR-3712E P

TR-3802E P + Nuisance Level* Organic Vapour

TR-3822E P + Nuisance Level* Acid Gas Filter
(Hydrogen Fluoride up to 10 x Workplace Exposure Limit)

*Nuisance level refers to concentrations below the occupational exposure limit (WEL).

Batteries

TR-330 Standard Battery

TR-332 High Capacity Battery



Belts

TR-325 Standard Belt TR-327 Easy-Clean Belt

TR-326 Leather Belt

Spares & accessories

TR-3600 Pre-filter TR-971 Air Flow Indicator

TR 371+ Filter Cover

BPK-01 Backpack TR-362 Spark Arrester

TR-329 Braces TR-380 Filter Surround Gasket

Chargers

TR-341E Single Station Battery Charger Kit

TR-344E 4-Station Battery Charger Kit

Typical applications

- ▶ Pharmaceutical
- ▶ Manufacturing
- ▶ Woodworking
- ▶ Surface preparation
- ▶ Food & beverage
- ▶ Metal working
- ▶ Smelting

3M™ Versaflo™ Powered Air Turbo TR-302E+

This unit comes with an airflow indicator and spark arrestors (x2). To adapt to your type of environment see options below.

3M™ Versaflo™ Starter Kit TR-315E+

This Versaflo Starter Kit includes the TR-302E+ Turbo, particulate filter, pre-filter, spark arrestors (x2), standard belt, high capacity battery pack, battery charger kit (not shown on the picture below), self-adjusting breathing tube and airflow indicator.



Note: 3M does not accept responsibility or liability, direct, indirect or consequential, arising from reliance upon any information provided and the user should determine the suitability of the products for their intended use. Nothing in this statement will be deemed to exclude or restrict 3M's liability for death or personal injury arising from its negligence or fraudulent misrepresentation.

Personal Safety Division

3M United Kingdom plc
3M Centre
Cain Road, Bracknell
Berkshire, RG12 8HT
Tel: 0870 60 800 60
www.3M.co.uk/safety

3M Ireland Limited
The Iveagh Building
The Park
Carrickmines
Dublin 18
1 800 320 500

Please recycle. Printed in the UK. © 2016 3M.
All rights reserved. J347991

